

Fig.1.1. Classification of Flynn

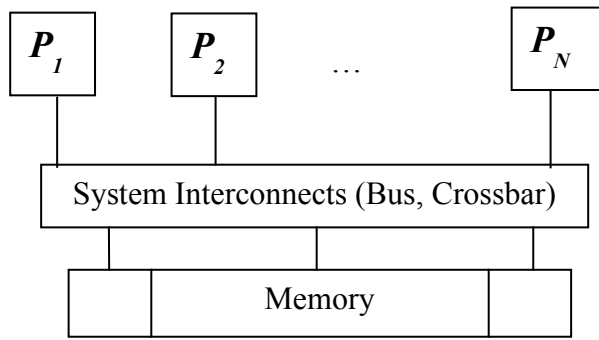

Fig.1.2. The UMA Model

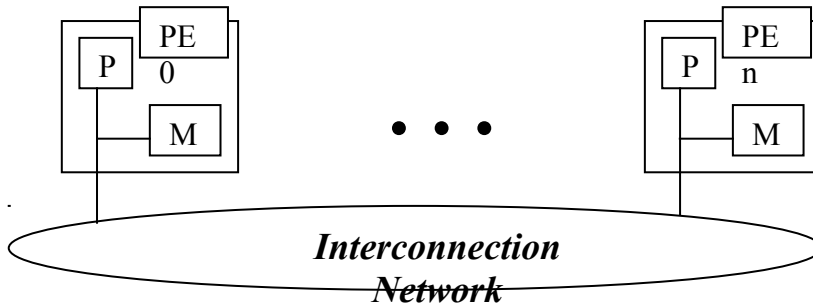

Fig.1.3. The NUMA Model

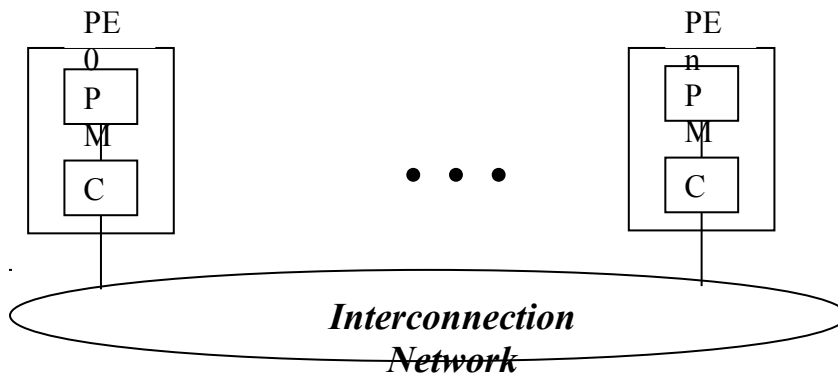

Fig.1.4. The COMA Model

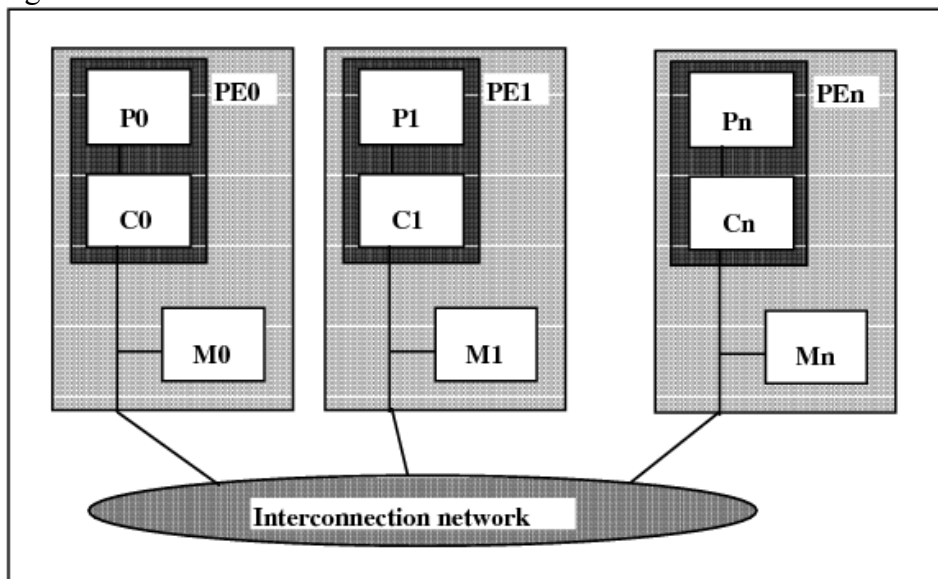

Fig.1.5. The CC-NUMA Model

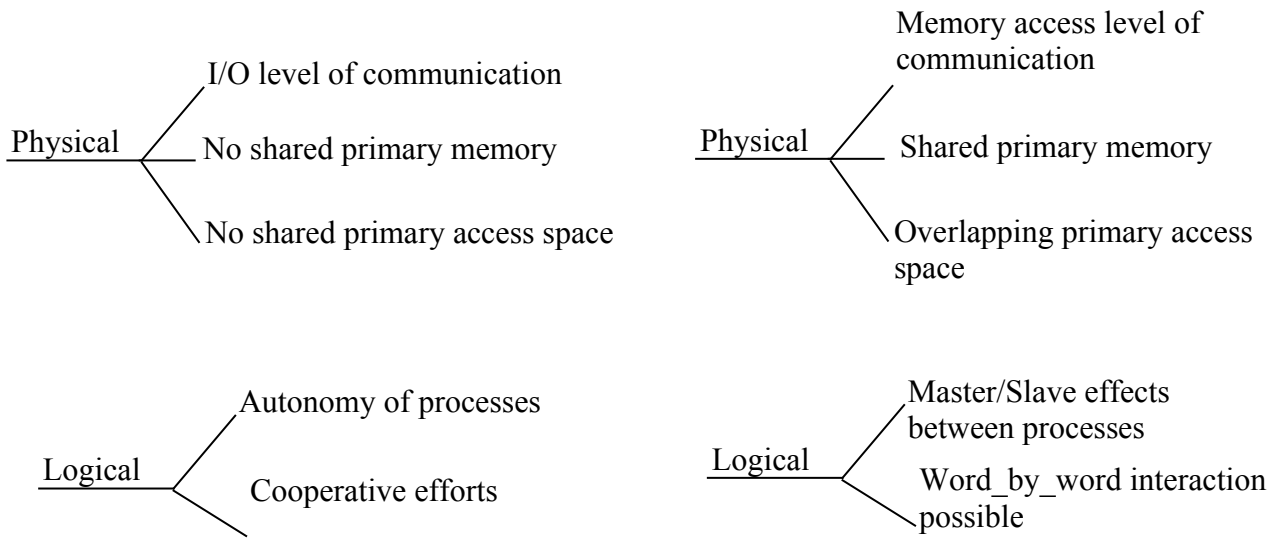

Fig.1.6. Granularity of multiprocessor systems

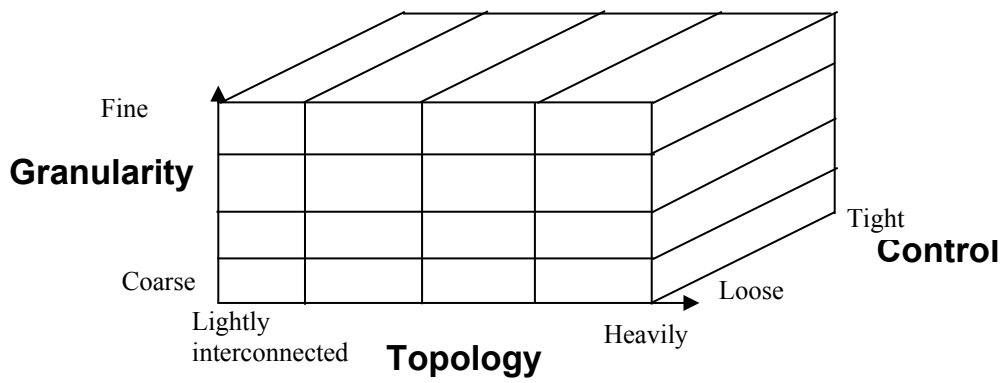

Fig.1.7. Multiprocessor Region in the Organization Space

